



Processing Student Comments on Understanding of Lecture Materials Using Rule Based Automata Finite State Model

Febri*¹ Suharmanto²

¹ Universitas Faletahan, Indonesia

² STIE Ganesha, Indonesia

febri@uf.ac.id¹, suharmanto@stieganessa.ac.id²

¹Address: Jl. Raya Cilegon Serang - Banten No.Km. 06, Pelamunan, Kramatwatu District, Serang Regency, Banten.

²Address: Jl. Legoso Raya No. 31 Pisangan Ciputat Timur, South Tangerang City

Author Correspondence : febri@uf.ac.id*

Abstract. Serang Raya University, is a private tertiary institution in the province of Banten, There are 4 faculties, Vocational D3 and 17 Study Programs, in the process of teaching and learning activities each lecturer has a different way of teaching students. Faculty of Information Technology, Computer Science Engineering study program with 30 lecturers, 9 classes, 59 courses and 126 students. This does not require the possibility that with the number of courses taken on campus there are still many students who do not understand what the lecturer is delivering. Management of student comments on the understanding of lecture material is designed to make it easy for students to comment on the lecturer's presentation of the material. This is also used as evaluation material for lecturers regarding the delivery of material. Currently, Serang Raya University does not have a website-based information system. From this discussion, comments are made with the Rule-based Finite State Automata model. In reading the comments, this produces a system that can read comments word by word until the end of the word with a space separator so that it finds keywords, namely the keywords understand and don't understand.

Keywords: Finite State Automata, College, Evaluation of Learning Outcomes, Online Learning, Prototyping

1. INTRODUCTION

Serang Raya University, is a private tertiary institution in the province of Banten, There are 4 faculties, D3 Vocational and 17 Study Programs, in the process of teaching and learning activities at Serang Raya University each lecturer has a different way of teaching students. There are those who apply a teaching system where the lecturer will always provide material and explain in full, but there are also lecturers who implement a teaching system where students make presentations, usually the University will hold a final student satisfaction assessment of the lecturer which is carried out in the semester, but does not yet have an assessment lecturers in the form of web-based comments to comment on lecture material delivered.

The research will be carried out at the Faculty of Information Technology, Computer Science Engineering study program. With 30 lecturers, 9 classes, 59 courses and 126 students. This does not require the possibility that with the number of courses taken on campus there are still questionnaires. A closed questionnaire is a questionnaire that contains closed questions that limit the respondent's answers by having to choose the answers listed in the questionnaire. While the open questionnaire is a questionnaire that contains open questions that allow respondents to give the desired answer in the words they choose themselves.

Received July 18, 2024; Revised: July 27, 2024; Accepted: August 21, 2024; Published 23, 2024

Answers from closed questionnaires are easy to analyze with rating scales and statistical techniques. Most researchers who study teacher evaluation focus only on quantitative data and ignore qualitative data. Student comments may contain subjective knowledge about a teacher, teaching methods, and presentation skills as well as suggestions for improving teaching quality.

2. RESEARCH METHODS

Applied Research

The system development research carried out is a type of Applied Research. Applied research is research aimed at obtaining a solution to a problem, the applied research model is more directed at creating innovation and developing science and technology. implementation of the analysis and design results using the Visual Study Code programming and SQL Server Database.

Finite State Automata readings

This reading with FSD was carried out by analyzing comments by word until finally keywords were found to determine the understanding of Q1 students as a state or condition, which can be described as follows:

Sampling/Metode Pemilihan Sampel

The data source was taken from the information technology faculty, computer systems study program, the number of samples consisted of 170 respondents, each respondent filled out a questionnaire consisting of NIM Class, Comments. From the three data, one sample data is taken, namely comments to be analyzed. The method of analysis is to count how many words you understand or don't understand in each student's comment by using a finite state automata so that it will produce output with a percentage of students who understand and do not understand for each course meeting.

3. RESULTS AND DISCUSSION

Research Results

Based on the results of research to determine student understanding in courses at Serang Raya University, this is done by analyzing comments using keywords to determine student understanding in learning that is being carried out in class by implementing the Finite State Diagram method in student assessments to determine understanding through comments made done . Here's the analysis.

Table 1. Student understanding of courses at Serang Raya University

KW1 (P)	=	KW2 (P)	=	Tidak Paham
KW1 (P)	=	KW2 (Na)	=	Tidak Paham
KW1 (NA)	=	KW2 (P)	=	Paham
KW1 (NA)	=	KW2(Na)	=	Tidak Terdeteksi

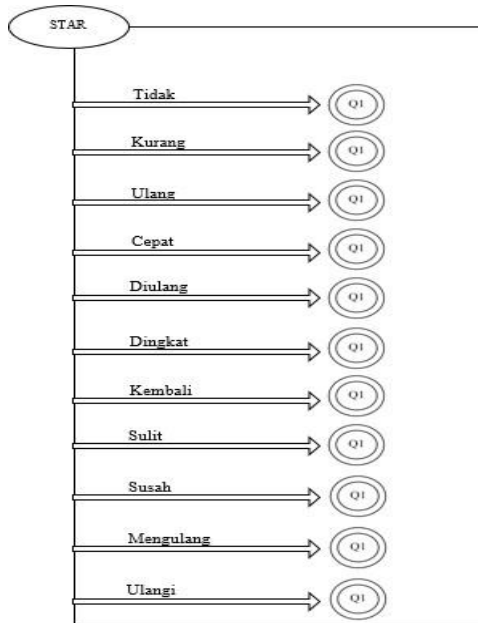

Information :

KW1=Keyword 1

KW2= Keyword 2

P = Kata Kunci Ditemukan

Keterangan :

KW1=Keyword 1

KW2= Keyword 2

P = Kata Kunci Ditemukan

Na = Tidak Ditemukan

Picture 1. the analysis

Table 2. Student understanding of courses at Serang Raya University

Keyword 1 TidakPaham	Tidak, Kurang, Ulang, Cepat,Diulang, Singkat, Kembali, Kurang, Sulit, Susah,Mengulang, Ualang
Keyword 2 Sudah Paham	Sudah, Paham, Memahami,Mudah, Dimengerti, Mengerti, Dipahami, Jelas

Research Discussion

In Processing Student Comments on Understanding Lecture Material Using the Rule- Based Finite State Automata Model to help

Finite State Automata Reading Machine

This machine is a reading of a finite state diagram program with the Finite State Automata machine model. Here are some illustrations and examples:

Finite State Automata, contoh inputan komentarnya:

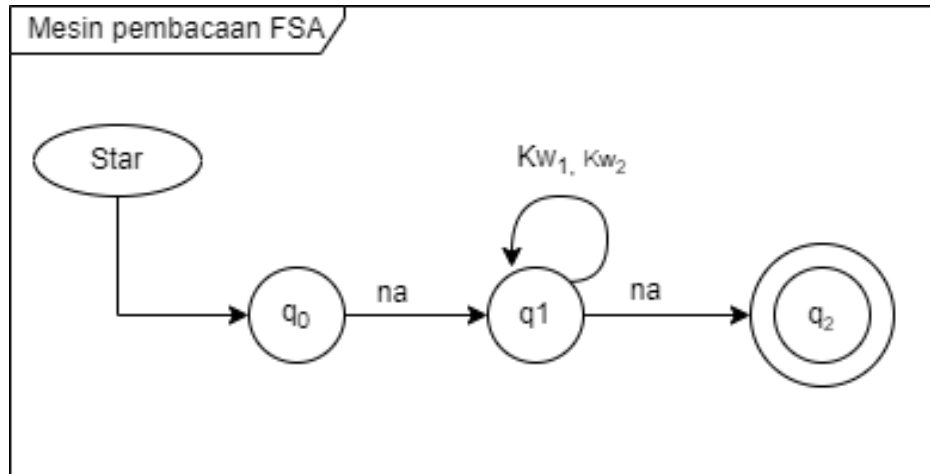

Picture 2. Finite State Automata

Input : saya mudah memahami penjelasannya

q0 Saya (na) q1 mudah (kw2) memahami (kw2) q2 penjelasannya (na) =
diterima mesin

Input : saya tidak paham

q0 Saya (na) q1 tidak (kw2) paham

(kw2) = ditolak mesin

Discussion

The purpose of the application of understanding lecture material from comment management is to increase enthusiasm for learning and be more active in socializing, therefore, what the campus needs is a comment management system to analyze a comment that is input by students to determine student understanding to improve student learning and make it as benchmark by the lecturer with what has been

Use Case Diagram

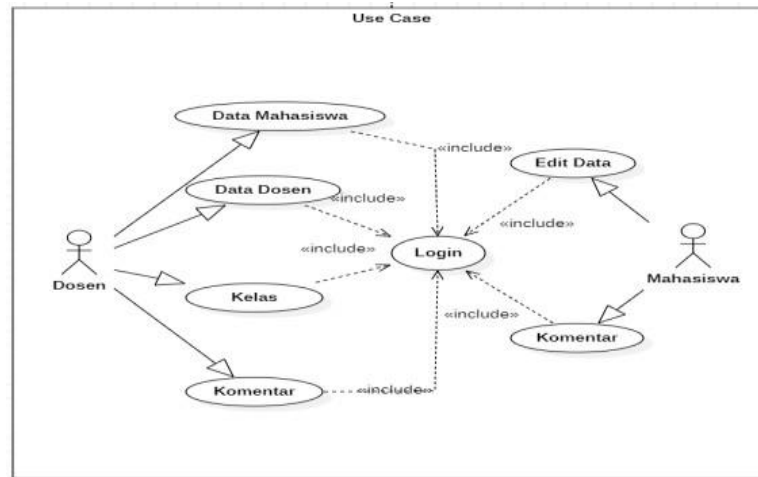

Picture 3. Use Case Diagram

4. CONCLUSIONS AND RECOMMENDATIONS

Based on the results of the research that has been done, the conclusions can be drawn as follows:

1. Processing Student Comments on Understanding Lecture Materials Using the Rule-Based Finite State Automata Model by reading cases up to the last word with a space separator.
2. From the management of student comments, you can find out which students already understand and do not understand the material presented, by reading to find keywords.
3. Helping lecturers to find out students who understand and do not understand the material they convey, so that it becomes material for evaluation by the lecturer in delivering the material so that the teaching and learning process becomes more optimal.

Suggestion

Maximizing the teaching and learning process so that learning becomes more optimal. In the future, because this model is still new to use, hopefully this research model can be reused with different or the same research and this program can be developed even better.

Suggestion

Maximizing the teaching and learning process so that learning becomes more optimal. In the future, because this model is still new to use, hopefully this research model can be reused with different or the same research and this program can be developed even better.

BIBLIOGRAPHY

- Asep Hidayatullah. (2022). Sistem pemahaman pembelajaran siswa dari pengelolaan komentar dengan model finite state diagram. *Jurnal Informatika dan Komputer*, Vol. 22, No. 2 September
- Burhanuddin Damanik¹, Markus Bangun² (2018). Evaluasi kinerja dosen univ.sari mutiara indonesia dengan menggunakan metode preference ranking organization method for enrichment evaluation (promethee). (*Journal of Computer Engineering System and Science*) p- ISSN :2502-7131 Vol. 3 No. 2 Juli
- Fatmasari (2022) , Analisis Sentimen Dalam Pengkategorian Komentar Youtube Terhadap Layanan Akademik dan Non-Akademik Universitas Terbuka Untuk Prediksi Kepuasan, *Building of Informatics, Technology and Science (BITS)* Volume 4, No 2, September 2022
- Giovani, A. P., Zamachsari, F., Agustono, E. D., Prasetya, M. I., & Gata, W. (2020). Implementasi Finite State Automata Dalam Siklus Pembelajaran Magister Ilmu Komputer STMIK Nusa Mandiri. *CESS (Journal of Computer Engineering, System and Science)*, 5(2), 221. <https://doi.org/10.24114/cess.v5i2.16696>
- Indah Nur Fitri Astuti¹, Irfan Darmawan², Dita Pramesti³ (2020) Analisis sentimen pada data kuesioner evaluasi dosen oleh mahasiswa (edom) prodi sistem informasi telkom university menggunakan algoritma support vector machine, *e-Proceeding of Engineering* : Vol.7, No.2 Agustus
- Isra Ul Huda (2022). persepsi mahasiswa terhadap pemahaman materi mata kuliah melalui proses pembelajaran daring pada mahasiswa stie pancasetia banjarmasin, *Jurnal Komunikasi Bisnis dan Manajemen* Vol . 9 No. 2 Juli
- Jamilah, M., & Nurmansyah, W. (2018). Aplikasi Alat Bantu Pembelajaran Visualisasi Finite State Automata (Versi : Pembuktian Graph Ke Tupel). *Jurnal Informatika*, 18(2), 151–161.
- Lelah, L., & Zaelani, M. Y. F. (2018). [20] Implementasi Finite State Automata Pada Aplikasi Pembelajaran Aksara Sunda. *Santika : Jurnal Ilmiah Sains Dan Teknologi*, 8(2), 777–785. <https://jurnal.ummi.ac.id/index.php/santika/article/view/395>
- Luh Gede Putri Suardani¹, Yoga Divayana², Komang Oka Saputra³ (2019). Analisis Komentar Hasil Belajar Siswa Menggunakan Opinion Summarization. *Majalah Ilmiah Teknologi Elektro*, Vol. 18, No. 1,
- Luh Gede Putri Suardani¹, Yoga Divayana², Komang Oka Saputra³, (2019), Analisis Komentar Hasil Belajar Siswa Menggunakan Opinion Summarization , *Majalah Ilmiah Teknologi Elektro*, Vol. 18, No. 1, Januari - April 2019.
- Masayu Jamilah ¹), Wawan Nurmansyah².(2018). Rancangan dan Implementasi Aplikasi Alat Bantu Pembelajaran Visualisasi Finite State Automata (Versi Pembuktian Graph ke Tupel). *Seminar Nasional Teknologi dan Bisnis*.

- Muhamad Mustaqim (2017). Model evaluasi pembelajaran stain kudus (studi kasus sistem evaluasi pembelajaran dosen prodi manajemen bisnis syari'ah stain kudus). Volume 5, Nomor 1, 2017: 155-169
- Muhammad Rusli¹, Mohammad Reza Faisal², Irwan Budiman³, Radityo Adi Nugroho⁴, Andi Farmadi⁵ (2020). Ekstraksi fitur menggunakan model word2vec pada sentiment analysis kolom komentar kuisioner evaluasi dosen OLEH MAHASISWA. Jurnal Ilmu Komputer (KLIK) Volume 07, No. 1
- Refi Riduan Achmad¹, Fahmi Fadillah Septiana², Nur Syamsi³, Bobby Suryo Prakoso⁴, Hafifah Bella, Novitasari⁵ (2021). Penerapan Finite State Automata pada Vending Machine dalam Melakukan Transaksi Pengembalian Buku di Perpustakaan. METIK VOLUME. 5 NOMOR. 1
- Riduan Achmad, R., Septiana, F. F., Syamsi, N., Prakoso, B. S., & Novitasari, H. B. (2021). Penerapan Finite State Automata pada Vending Machine dalam Melakukan Transaksi Pengembalian Buku di Perpustakaan. Metik Jurnal, 5(1), 63–70. <https://doi.org/10.47002/metik.v5i1.219>
- Siregar, R. R. A., Siregar, Z. U., & Arianto, R. (2019). Klasifikasi Sentiment Analysis Pada Komentar Peserta Diklat Menggunakan Metode K-Nearest Neighbor. Kilat, 8(1). <https://doi.org/10.33322/kilat.v8i1.421>
- Soepomo, P. (2014). Media Pembelajaran Teori Bahasa Dan Otomata Pokok Bahasan Finite Automata (Fa) Berbasis Multimedia. Jurnal Sarjana Teknik Informatika, 2(1), 140–149.
- Sri Wulan Utami Vitandy¹, Ahmad Afif Supianto², Fitra Abdurrachman Bachtiar³ (2019) Analisis Sentimen Evaluasi Kinerja Dosen menggunakan Term Frequency-Inverse Document Frequency dan Naïve Bayes Classifier, Jurnal Pengembangan Teknologi Informasi dan Ilmu Komputer e-ISSN: 2548- 964X Vol. 3, No. 6, Juni
- Syafii, M. H. (2022). Penerapan Konsep Finite State Automata Untuk Penjurusan Ipa Atau Ips. METHOMIKA Jurnal Manajemen Informatika Dan Komputerisasi Akuntansi, 6(1), 34–39. <https://doi.org/10.46880/jmika.vol6no1.pp34-39>
- Vina N. Van Harling (2021). Analisis hubungan tingkat pemahaman materi perkuliahan pengantar ilmu lingkungan dengan menggunakan google classrrom terhadap hasil belajar mahasiswa. Jurnal pendidikan dan kewirausahaan volume 8 No 2 ISSN: 2623-1964
- Vitandy, S. W. U., Supianto, A. A., & Bachtiar, F. A. (2019). Analisis Sentimen Evaluasi Kinerja Dosen menggunakan Term Frequency- Inverse Document Frequency dan Naïve Bayes Classifier. Jurnal Pengembangan Teknologi Informasi Dan Ilmu Komputer, 3(6), 6080–6088. <https://j-ptiik.ub.ac.id/index.php/j-ptiik/article/view/5645>
- Wartini. (2016). Perancangan Aplikasi Media Pembelajaran Teori Bahasa Automata Menggunakan Metode Computer Assisted Instruction (CAI) Berbasis Multimedia. Majalah Ilmiah Informasi Dan Teknologi Ilmiah, XI(1), 78–81.